

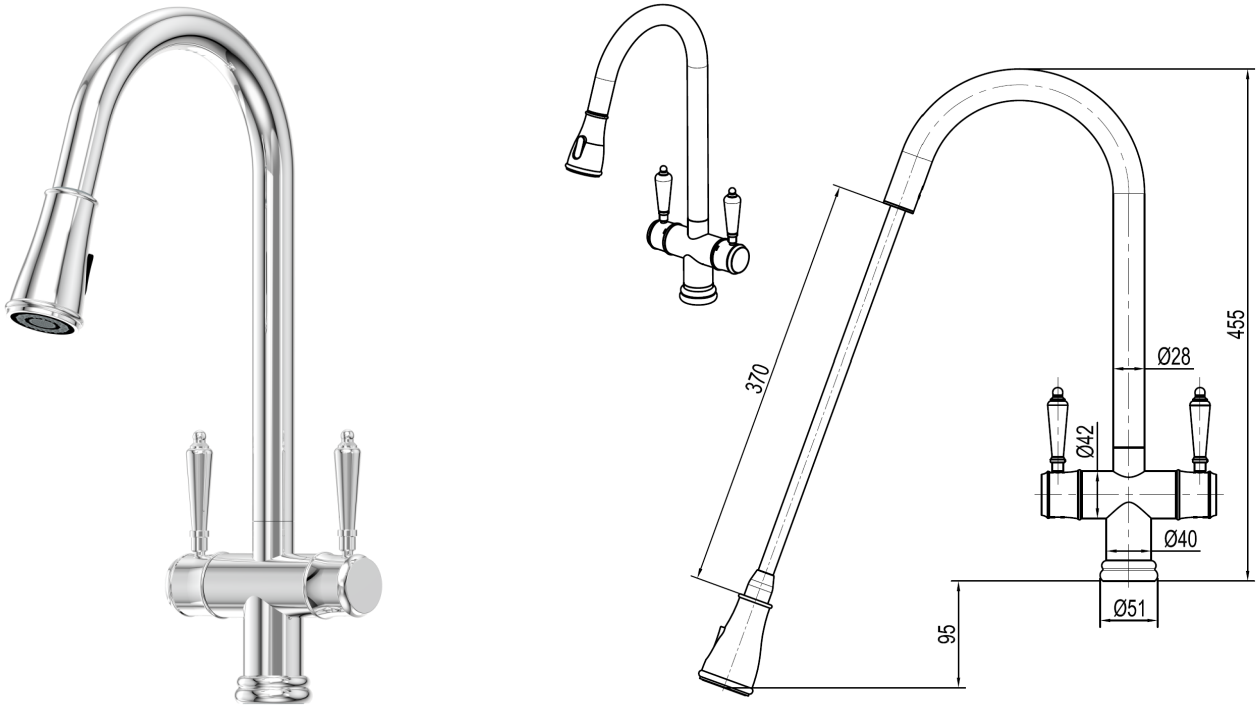

# XQUISITE – XFIT1030RKM / XFIT1030RKM\_CP / XFIT1030RKM\_GM



Note: Drawings are not to scale and are for reference only. Specifications and sizes can be changed by the manufacturer without notice. Refer to physical unit prior to installation.

## Product Specifications

Base Material	316 Marine Grade Stainless Steel	
Finish	Satin / Chrome Plated / Gunmetal	
Installation	Xpressfit Top Mount	
Height	455mm	
Projection	233mm	
Features	Provincial styling Separate hot and cold handles Retractable dual pattern spray nozzle 370mm pull out length (excl. nozzle) Rotating swivel ball joint nozzle	
WELS Rating	5 star water efficiency, 6.0L per minute	
Warranty	2 years parts and labour, 15 years replacement on cartridge and PEX inlet hoses	