

X-CLASS – XFIT200SKM / XFIT200SKM_MB/ XFIT200SKM_GM
 XFIT200SKM_RG / XFIT200SKM_SG

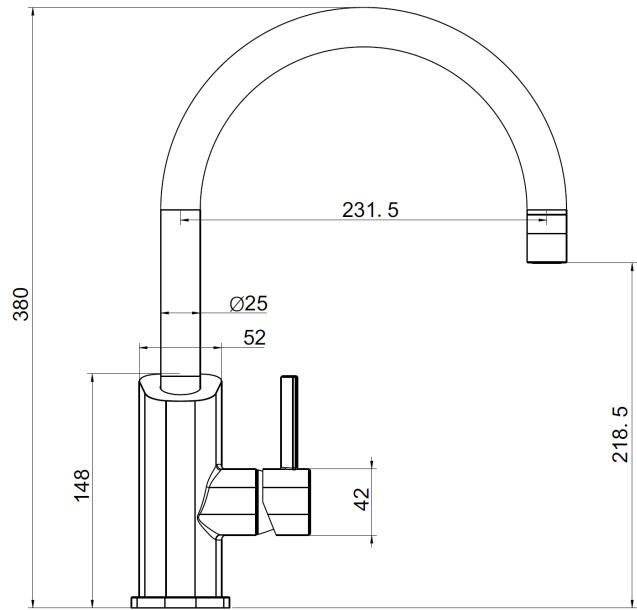

Note: Drawings are not to scale and are for reference only. Specifications and sizes can be changed by the manufacturer without notice. Refer to physical unit prior to installation.

Product Specifications

Base Material	304 Stainless Steel	
Finish	Satin / Matt Black / Gun Metal / Rose Gold / Brushed Gold	
Installation	Xpressfit Top Mount	
Height	380mm	
Projection	231.5mm	
WELS Rating	4 star water efficiency, 7.5L per minute	
Cartridge Size	35mm	
Warranty	2 years parts and labour, 15 years replacement on cartridge and PEX inlet hoses	