

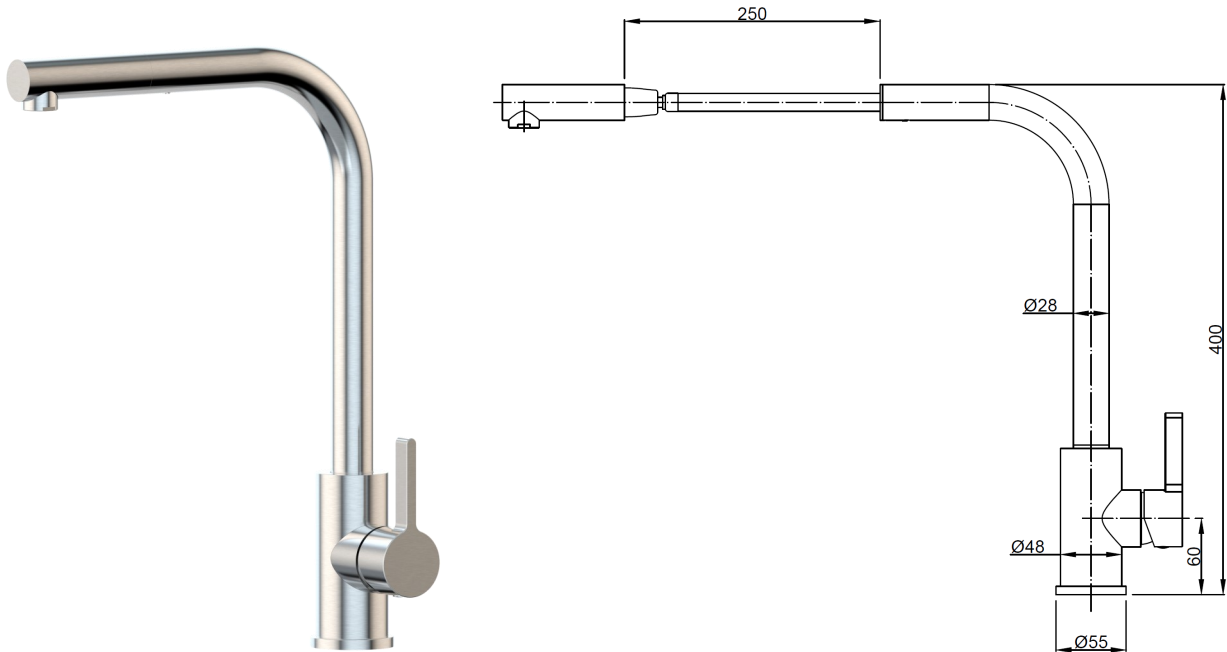

**XCLAIMER** – XFIT910RKM / XFIT910RKM\_CP / XFIT910RKM\_PS  
 XFIT910RKM\_BC / XFIT910RKM\_BP / XFIT910RKM\_GM /  
 XFIT910RKM\_RG



Note: Drawings are not to scale and are for reference only. Specifications and sizes can be changed by the manufacturer without notice. Refer to physical unit prior to installation.

**Product Specifications**

Base Material	304 Stainless Steel	
Finish	Satin / Chrome Plated / Polished / Black & Bling / Gun Metal / Rose Gold	
Installation	Xpressfit Top Mount	
Height	400mm	
Projection	244.5mm	
Features	High flow nozzle 250mm pull out length (excl. nozzle)	
WELS Rating	3 star water efficiency, 9.0L per minute, Reg. T35490	
Cartridge Size	35mm	
Warranty	2 years parts and labour, 15 years replacement on cartridge and PEX inlet hoses	